

Flange NO 100, NP 16

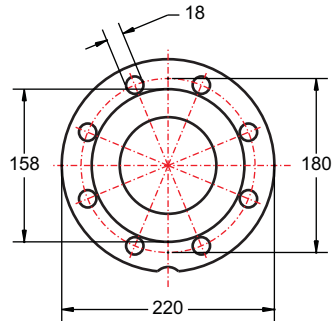

Flange on request :
NO 100, NP 6

Pump Type	Elektromotor				L mm	Mass kg
	Type	kW	A	r.p.m		
NCP 100-1	1ZK 100 Ld4	3	6.5	1410	594	84
NCP 100-2	1ZK 100 L4	2.2	5.0	1400	594	77
NCP 100-3	1ZK 90 L4	1,5	3,8	1420	541	61

Comprex NCP100 - 1450 r.p.m

Temperature Range : -20 to +140 °C

System pressure: NP 6 (bar)

Materials:

For temperatures up to + 90 °C:

Cast iron, stainless steel

Mechanical seal: Carbon / Ceramic.

For temperatures above +90 °C:

Cast iron, stainless steel and bronze.

Mechanical seal: SiC / SiC / Viton.

Allowed fluids:

Domestic or industrial water without abrasive

Heating water to VDI 2035

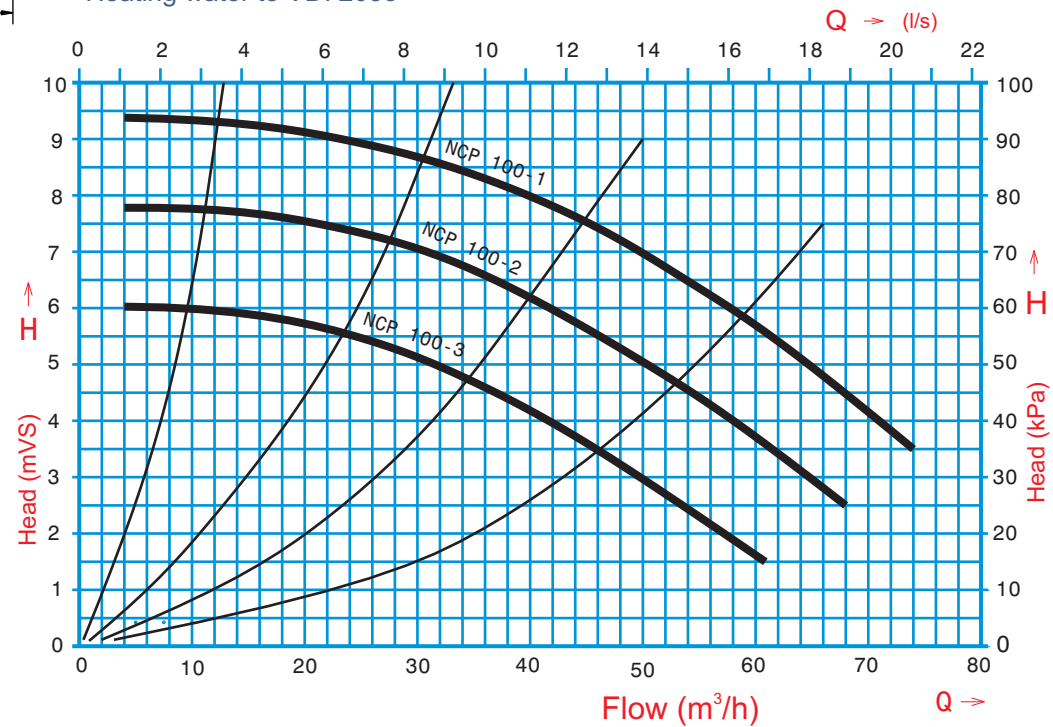

Type testing of pumps is made at the Institute for Hydraulic Machines faculty of Mechanical Engineering in Belgrade, in accordance with the recommendations of DIN 1944 and ISO 2548th. Report number: 06-01-03/95