

Drainage cell (drain pump)

Comprex DVP

Duty graph

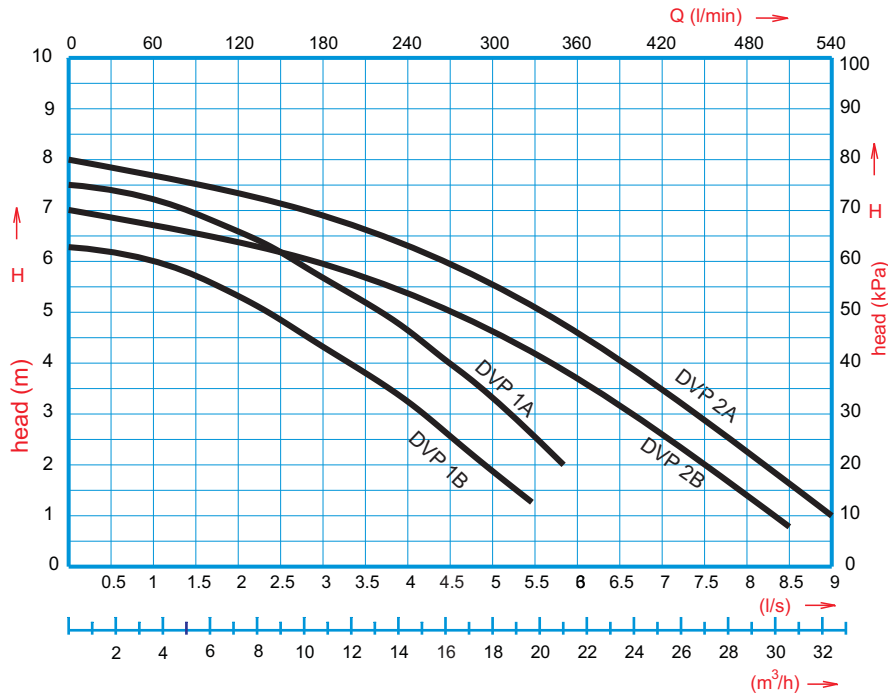

Pump type	Impeller diameter	Electromotor 3x380 V 50 Hz			
		Type	Power (kW)	(A)	r.p.m
DVP 2A	162	90 L-4	1,5	3,8	1420
DVP 2B	152	90 S-4	1,1	2,8	1400
DVP 1A	160	80 B-4	0,75	2,1	1400
DVP 1B	145	80 A-4	0,55	1,7	1380

Typical length of the pump are: L = 750, 1000, 1500 and 2000 mm, and can be ordered any length from 500 to 2000 mm.

Purpose

Drainage cells DVP are used primarily for automatic watering easily soiled and moderately aggressive wastewater, including storm water and groundwater. Pumped liquid may contain up to 5% of particulate matter other than a long fiber

Construction and function

Drainage cells was performed as a complete unit mounted on a square steel plate, which is placed directly on collecting a well with an opening 500x500 mm. The basic components of cells are single stage pump, motor and control panel. Electric motor mounted on a steel plate and a pump submerged in the pumped liquid are connected by an extended shaft and bearing pipes. Control panel contains elements of automation, protection and signaling. Control panel may be installed on the steel plate (as shown), but it is recommended to be placed on the wall of the room near the pump. The pump is designed to work in manual and automatic mode. The automated drain station is controlled by level switch, which signals for starting and stopping of electric motors get through the level probe. In case of danger from the occasional massive influx of waste water, it is possible to supply the pump with two-speed motor (1400 / 2800 rpm). When the water level reaches the critical point automatically triggers greater speed and sound and light alarm. At a speed of 2800 rpm the flow is increased about 2 times

Material

The material used for making pumps are cast iron SL 250, stainless steel C 4171, galvanized steel pipes and polyacetal of whom made bearing cartridge

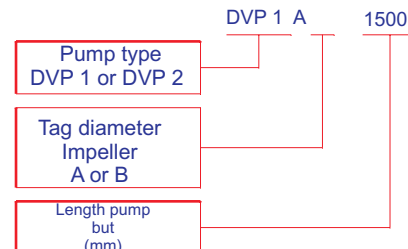
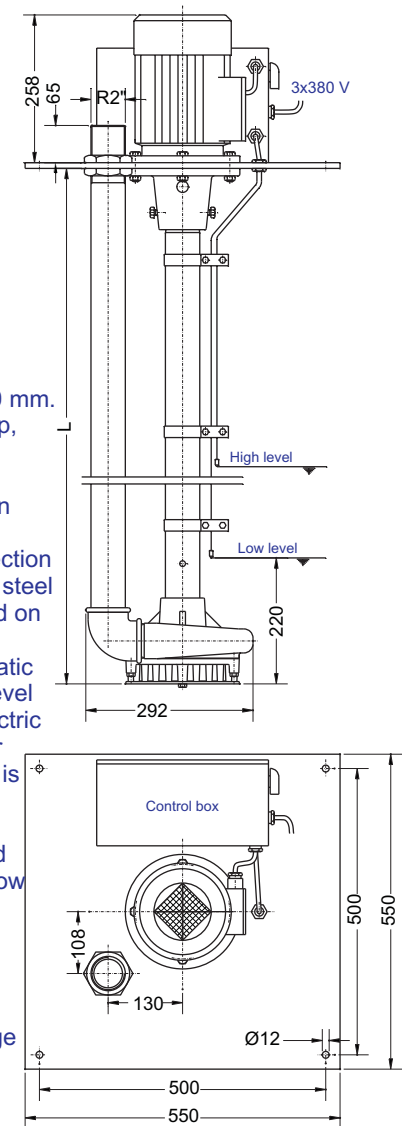

* Control box is made in the protection of IP 54. On request, can also be supplied with a greater degree of protection.

** two-speed pump motor has additional emblem - the DBM